

A | B | C | D | E | F | G | H | I | J | K

1
2
3
4
5
6
7
8

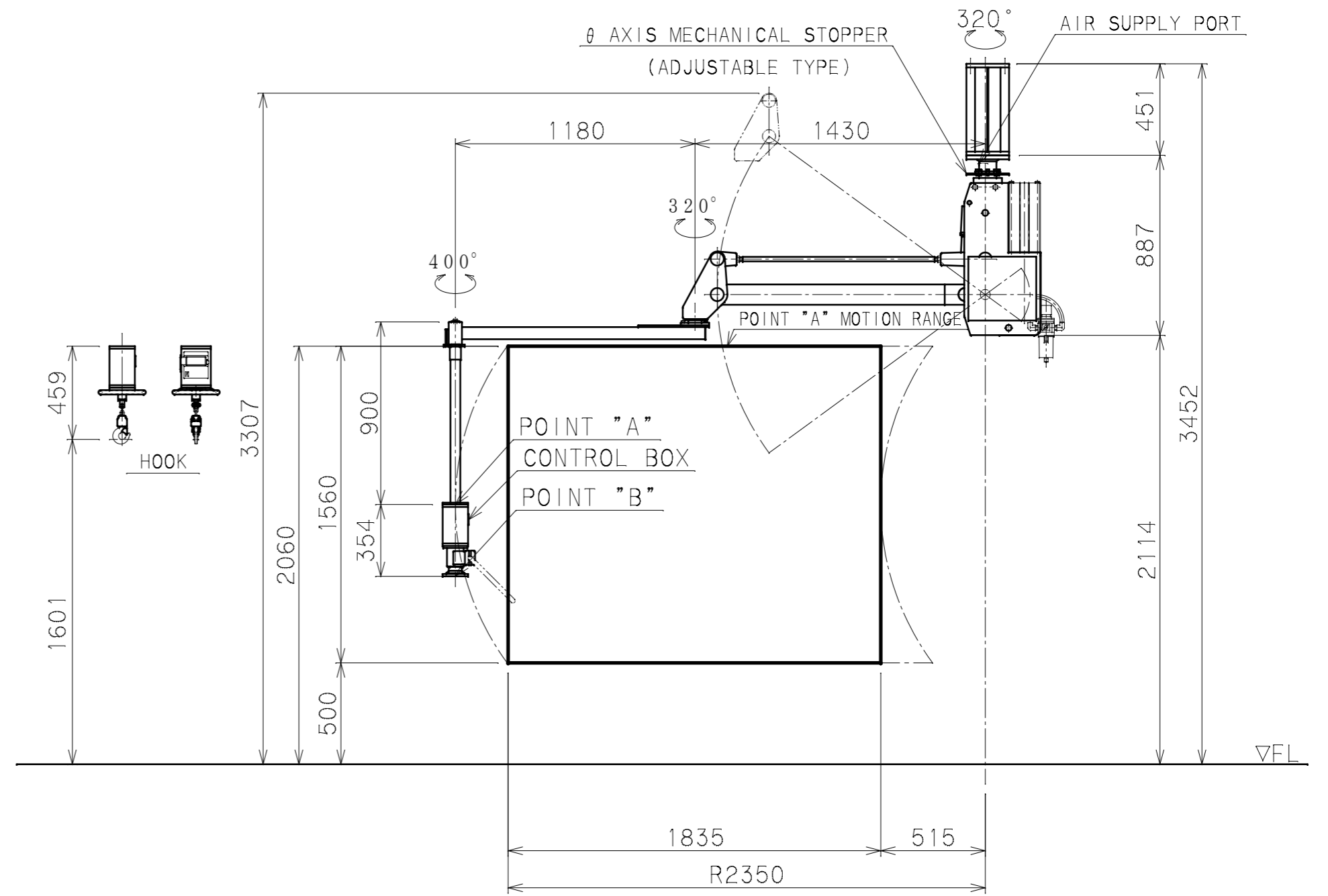
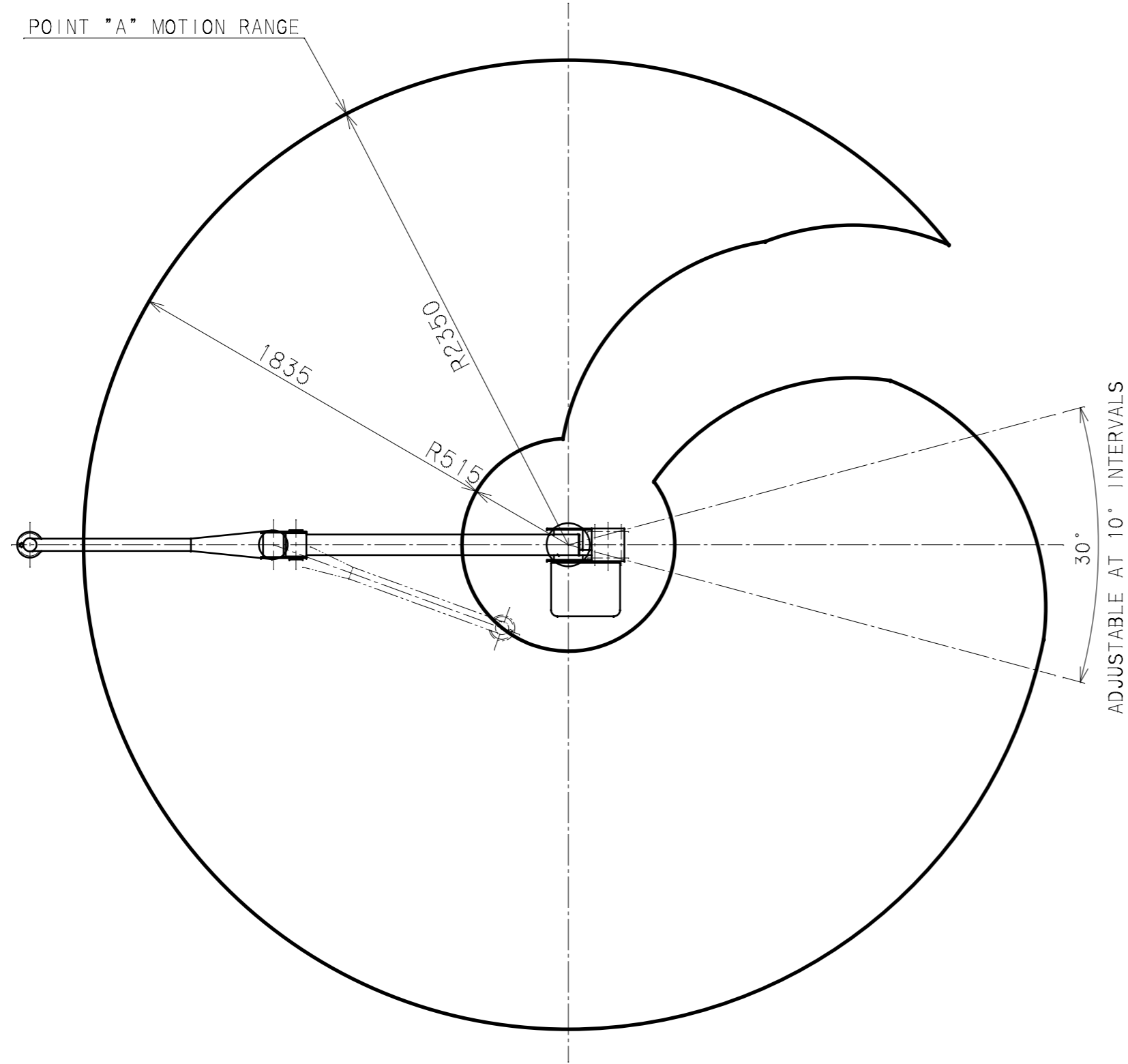

BALAMAN SPECIFICATIONS	
MODEL	U2BMS-75C θ AXIS MECHANICAL STOPPER (ADJUSTABLE TYPE)
MAX. LOAD	75kg (BELOW POINT "A") 63kg (BELOW POINT "B")
MAX. RADIUS	R2350 mm
HORIZONTAL STROKE	1835 mm
VERTICAL STROKE	1560 mm
MAX. WORKING HEIGHT	2060 mm
MAX. MACHINE HEIGHT	3307 mm
AIR SUPPLY	0.54 MPaG
AIR CONSUMPTION	133NL/min (10 SEC CYCLE)
POWER SUPPLY	SINGLE-PHASE AC85~AC264V 50/60Hz 0.1KVA
CONTROL METHOD	
COATING	LN-15 (JPMA BLACK) LN-93 (JPMA WHITE)
MAIN UNIT MASS	APPROX. 150kg
BASE UNIT MASS	APPROX. 15kg
CONTROL BOX MASS	12kg
WORKPIECE MASS	kg
REMARKS	ACCESSORIES: PRESSURE REDUCE SET : POWER SUPPLY BOX